



## **Owners' Manual and Installation Guide**

*INCLUDING*

**BASS MEKANIK**

*T-CLASS DIGITAL AMPLIFIERS*

**HAND - CRAFTED IN FLORIDA,  U. S. A.**

Thank-you for choosing U.S. Amps! You have purchased the finest product of its type available. Each U.S. Amp is built *by hand* in our Gainesville, Florida factory. Nothing is done "off shore" or across the border. You won't just *listen* to your U.S. Amp, you will *experience* it. When properly installed, this unit will provide years of trouble-free service..

This manual is written for the experienced installer. Please read it in its entirety before installation. If you are unfamiliar with the terminology and concepts within, we strongly recommend you seek the assistance of an Authorized U.S. Amps Dealer or other car audio professional. Authorized Dealers can be located on the U.S. Amps website: [www.usamps.com](http://www.usamps.com), or by calling the U.S. Amps Factory - Monday thru Friday at (352)-338-1926, 9am to 5pm EST. Our 24 FAX line is (352)-371-4122. Remember, protect your hearing and enjoy your U.S. Amp!

## Table of Contents:

<b>Installation:</b>	<b>3</b>	<b>USA-2000 / 2000X-</b>	<b>16</b>
<b>Active Electronic Crossovers:</b>	<b>4,5</b>	<b>USA-4300X-</b>	<b>17,18</b>
<b>Bridging Your U.S. Amp-</b>	<b>6,7</b>	<b>USA-5600X-</b>	<b>19,20</b>
<b>Getting Wired-</b>	<b>8</b>	<b>BASS MEKANIK T-CLASS EXPLAINED-</b>	<b>21-23</b>
<b>Batteries-</b>	<b>8,9</b>	<b>PT-350-</b>	<b>24</b>
<b>Amplifier Protection-</b>	<b>9</b>	<b>PT-800, PT-1100-</b>	<b>25</b>
<b>Amplifier Specifications-</b>	<b>10,11</b>	<b>Factory Warranty Service-</b>	<b>26</b>
<b>USA-200 / 200X, USA-400 / 400X-</b>	<b>12,13</b>	<b>Limited Warranty-</b>	<b>26</b>
<b>USA-50HC, USA-100HC, USA-600 / 600X, USA-1000 / 1000X-</b>	<b>14,15</b>	<b>Never-Never Land-</b>	<b>27</b>
		<b>Other Cool Stuff-</b>	<b>27,28</b>

### Did you buy the right U.S. Amp?

There is a U.S. Amp for every purpose. If your needs require maximum amplifier power into 4 or 2 ohms per channel, or 4 ohms bridged, use one of the Xterminator "X" models for the best results. If you have more than a pair of speakers, or if the speakers have multiple voice coils, you may need the extra current and low impedance stability of the USA Series. The USA Series develops maximum output when used at 1 ohm per channel or 2 ohms bridged. If you participate in sound-off events, the "HC" (High Current) amplifiers are designed to operate at ultra-low impedances.

# INSTALLATION

## **Amplifier Mounting:**

Choose an appropriate location to mount the amplifier(s). Make sure your choice is free from excess heat, moisture, and vibration. Under the vehicle seat or in the trunk are common mounting locations. Be sure the amplifier receives adequate ventilation to its heat sink and is positioned away from flying luggage and people's feet. Do not mount the amplifier directly to speaker enclosures.

## **Ventilation:**

It is important to provide the amplifier with adequate ventilation to remove heat from the amplifier heat sink. During high performance applications, in which the amplifier may be exposed to low impedance loads, it may be necessary to provide external ventilation via a fan or some other means. With proper ventilation, the "run time" of the amplifier between thermal protection cycles can be greatly extended.

## **Amplifier and Crossover Input:**

U.S. Amps feature a unique isolated input section that will accept signal voltages from 250 mv to 10 volts. The input section also provides amplifier ground isolation for the prevention of system and engine noise. The unique configuration of the U.S. Amps input necessitates a correct input ground, and is not compatible with external ground-isolation devices.

# **IMPORTANT NOTICE**

**The input of a U.S. Amp MUST be grounded for proper amplifier operation.  
The use of external ground isolation dividing devices is unnecessary  
and may cause severe amplifier and / or system damage.**

## **Signal Level (BTL) Input:**

This product will accept line and signal level, and can be used with most BTL "high powered" sources. To use a BTL source, observe the following:

- 1) BTL outputs have two "hot" non-grounded leads per channel. Select ONE per channel, and connect it to the "center conductor" of the RCA input cables going to the amplifier input.
- 2) Insulate and disregard the second wire of each BTL output pair.
- 3) Ground the shield wires of the RCA cable to the metal body of the source unit.

## **Gain Control Adjustment:**

Always start with the gain control fully counter-clockwise (all the way down), or just slightly open. Adjust the source unit volume as high as possible without distortion. Increase the amplifier gain until the amplifier distorts, then turn the gain down slightly until the signal becomes clear. It is desirable to operate the amp at the lowest possible gain setting to help reject spurious system noise.

# ACTIVE ELECTRONIC CROSSOVERS

# US-X2

The US-X2 and US-X2R are two-way crossovers that “split” the full-range audio signal into two groups of frequencies- high and low. Each group is sent to a dedicated amplifier, which in turn, powers a speaker or speakers that are best suited to play those frequencies. Both units have independent controls to adjust the “roll-off” of the high and low frequencies from 50Hz to 500Hz at 12 Db per octave.

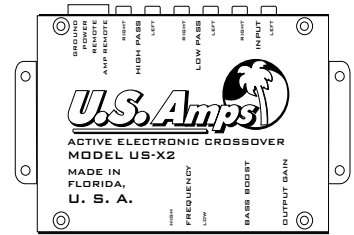

The low frequency control limits the high frequency response of the low pass output, and the high frequency control limits the low frequency response of the high pass output. Both units feature a variable Bass Boost that emphasizes frequencies in the 65Hz range up to 20Db. The US-X2R is a more featured unit with dual inputs and two high pass outputs that can be independently adjusted. The US-X2R will “fade” between two mid and high amps, but if only one input pair is available, the dual input can be defeated.

The US-X2R comes with an optional “Remote Bass Gain” or “RBG” that can be mounted in the passenger compartment to independently attenuate the low pass output. The Bass Gain located on the cut-away side of the unit is used both to set the level of the low pass output and control the range of the RBG. It does not matter which way

# US-X2R

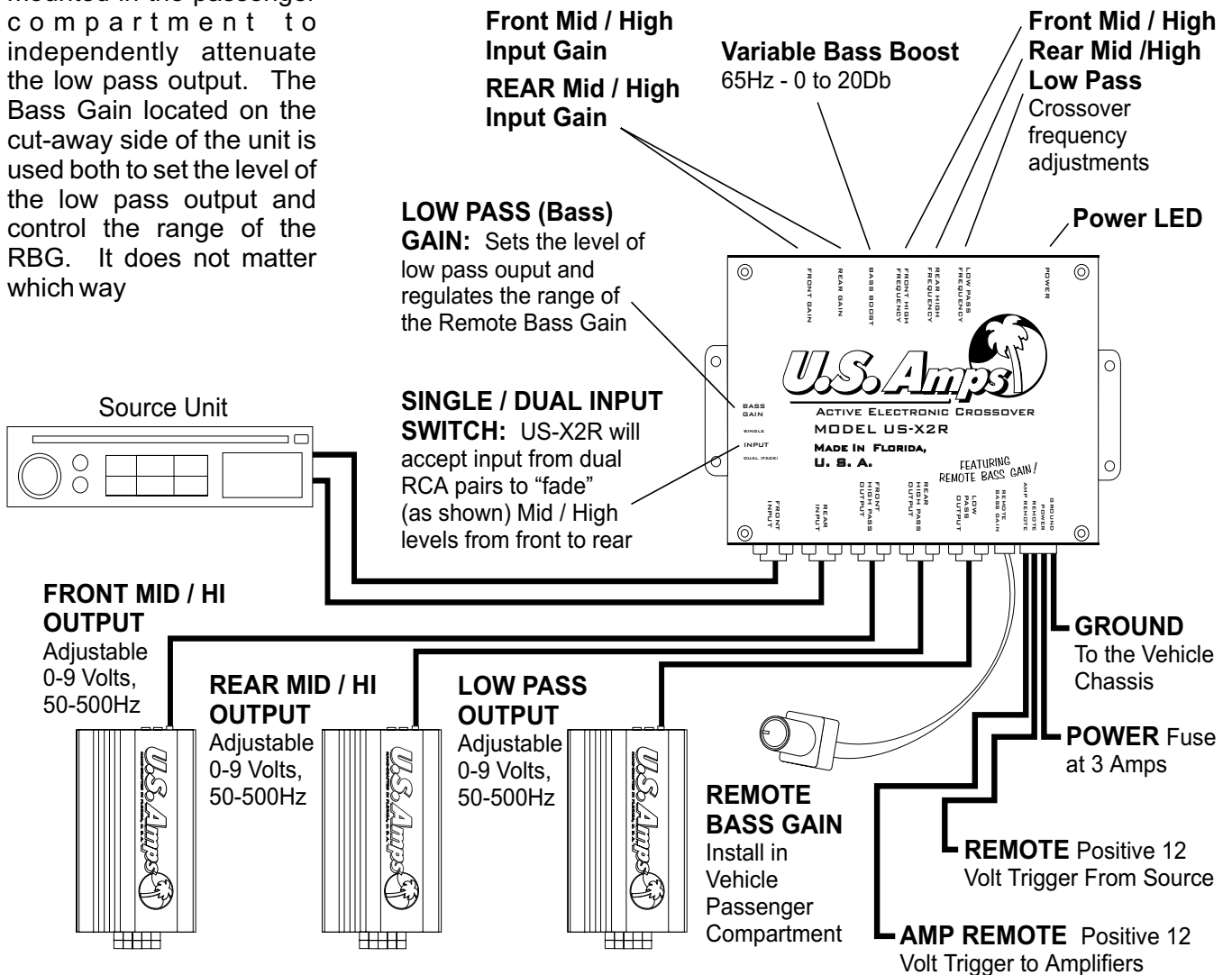

the RBG cable is connected. Use a common screwdriver tip or something like it to tighten the RBG knob.  
 The US-X3 is a three-way unit that further divides the frequencies for three amplifiers. The features and operation are similar to the others with the addition of the third mid range channel, and its gain. There are separate high, mid and low mid frequency controls, and the mid range output can be inverted 180 degrees with a switch to correct for real-life speaker placement.

# US-X3

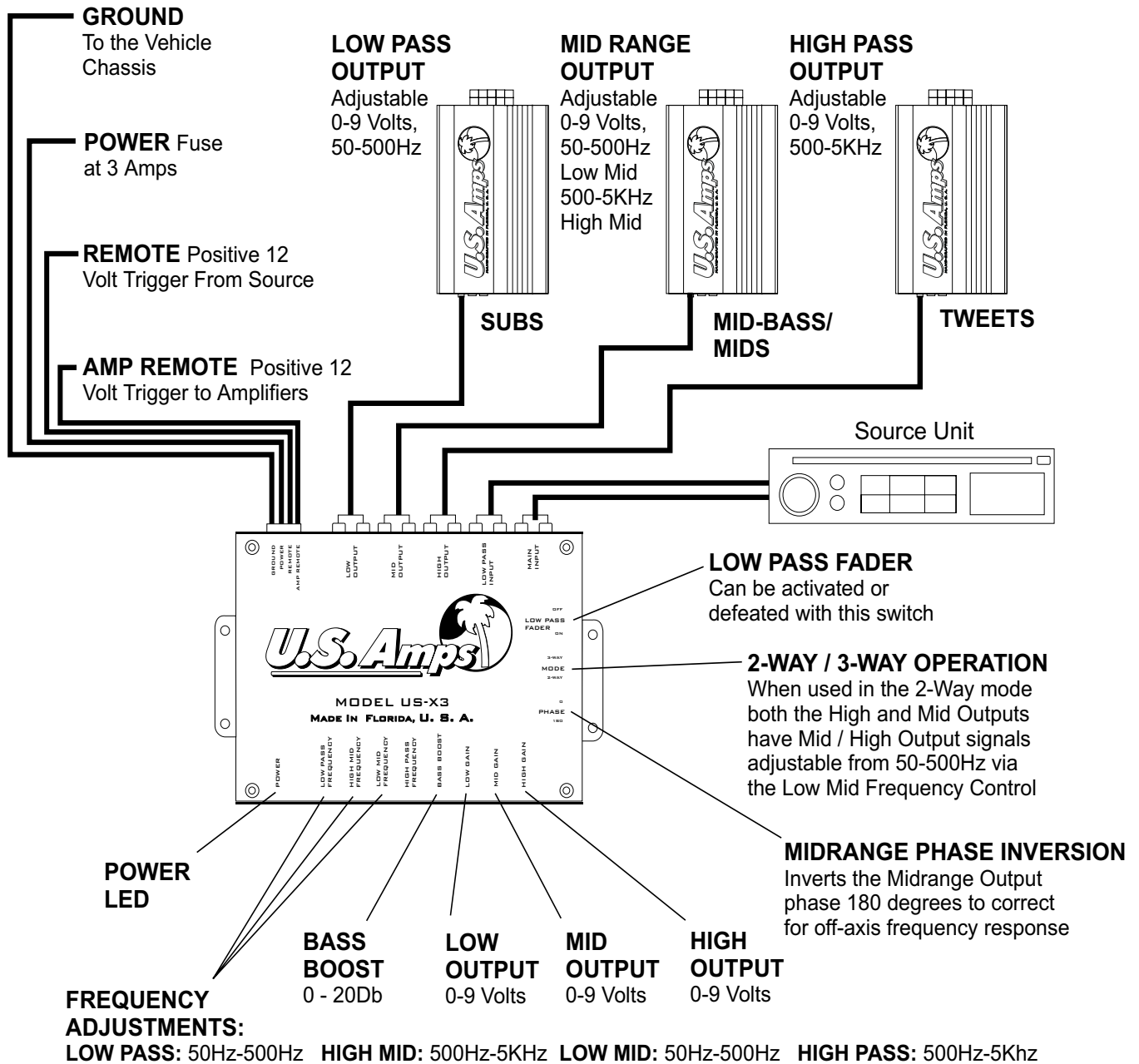

U.S. Amps crossovers feature an isolated input and amplifier section to keep the system free of noise. It is important to ground the crossover input for proper operation. Do not use a floating ground isolator with this or any other U.S. Amps product.

## **BRIDGING YOUR U.S. AMP**

All U.S. Amps listed in the following section can be used in the BRIDGED mode, meaning that both channels of the amplifier are used together as a powerful single channel, usually to drive a group of subwoofers. Since subwoofers come in a wide variety of types and impedances, U.S. Amps makes different groups of amplifier models to work best with specific speaker systems. To get the most power from your amp, match it by model and code to one of the following diagrams. Great care has been taken to optimize your amplifier's performance when wired as recommended, so please follow these diagrams carefully. The on-board SAT "SMART AMP TECHNOLOGY" protection circuit on the USA-150, 300, 700T, and 2000 types carefully monitors and records amplifier performance, including the suitability of the load in comparison with the amplifier type.

## **SPEAKER MYSTERIES EXPLAINED**

Think of the speaker as an electric motor and the Amp as the wall-current that makes it "run". The two principals in fact, are very similar. All speakers have a motor, consisting of the permanent magnet at the rear of the speaker and a "voice coil" that attaches to the speaker cone and rides back in forth in the center of the magnet. Just like a motor you would plug into the wall and say, vacuum the floor, the amp powers the voice coil which in turn reacts to the permanent magnetic field by pushing and pulling against it. The resultant motion moves the speaker cone and wall-la! You have sound! (Normally U.S. Amps wouldn't care about speakers, but we have been asked to explain this function in greater detail-Harrumph!)

Each voice coil has a resistance, or impedance, that is crucial to the way it reacts with a given model of U.S. Amps and vice versa. This resistance is measured and expressed in OHMS, or *Ohms of resistance*. Put simply, OHMS are the things that keep the amplifier speaker leads from shorting together, which is a no-no. The less OHMS a speaker has, the closer the electrical potential of the amplifier will be to shorting.

Speakers are typically available with 8, 4, or 2 ohm coils. There is a great deal of difference between these ratings, as with the order of magnitude of the numbers 8,4, and 2 themselves. As 4 is TWICE as much as 2 and 8 is TWICE as much as 4, the amount of current an amplifier must provide to drive a 4 ohm speaker is TWICE that required to drive an 8 ohm speaker, a 2 ohm coil requires TWICE the current of a 4 ohm coil. While all this seems academic, is nonetheless of vital importance, and is perhaps the most overlooked and unfortunate reason for expensive system failure. Just like an electric motor and the wall socket, it is possible to stack more motors on the circuit than it can handle.

## **HIGH CURRENT OR HIGH VOLTAGE?**

Before you form the opinion that higher current amps are obviously better, forget it. High current is simply a way to get power under a different circumstance. All amplifiers have current and voltage. Really, one comes at the expense of the other, but they are both equally effective at delivering power. "Power" is measured in WATTS, like a light bulb, and is the product of a mathematical equation that takes into account the current and voltage output of the amplifier in relation to the resistance, or OHMS of the voice coil or voice coil combination. (Impedance is another word for resistance, and the two are often interchangeable.) Let's totally geek out together and examine this formula, as it will help you understand the role voltage and current play in relation to speaker impedance and power:

The equation is kind of divided into 2 parts. If you take the time to check this out, you will see what is REALLY COOL about amplifier bridging, and why it is so important to pay attention to the numbers.

**PART ONE:**

$$\mathbf{VOLTS \div RESISTANCE = CURRENT}$$

**WORKING MODEL:**

You have a two-channel amplifier. Each channel that has 20 VOLT “power rails”.  
You have a speaker with 4 OHMS of RESISTANCE.

If you hook ONE CHANNEL to the speaker and do the math:

$$\mathbf{20 \div 4 = 5}$$

”5” is AMPS OF CURRENT. (“AMPS” and “CURRENT” are another one of those interchangeable words.) Next, we will use the answer of this first part and the “rail voltage” to determine WATTS OF POWER.

**PART TWO:**

$$\mathbf{VOLTS \times CURRENT = WATTS}$$

$$\mathbf{20 \times 5 = 100}$$

So, whaddya know? You’re putting out 100 WATTS! Well, that’s all fine and dandy until you BRIDGE your amp. There is hidden mathematical advantage in doing so, and the only thing that can hold you back are THE LAWS OF PHYSICS. Each channel of your amp has a positive and negative “rail voltage”. Engineers speak of “power rails” when they refer to amplifier voltage, hence the name. Your 20 VOLT amp REALLY has a POSITIVE 20 VOLTS and a NEGATIVE 20 VOLTS, but you are only using HALF of it for each channel. So, you break bad with the built-in bridging capability of your U.S. Amp, and all of a sudden you have a single 40 VOLT BRIDGED CHANNEL.

SO, LETS’ SUBSTITUTE 40 VOLTS FOR 20 AND DO THE MATH:

$$\mathbf{40 \div 4 = 10}$$

AND HOW MANY WATTS IS THAT?

$$\mathbf{40 \times 10 = 400}$$

Yes, Pilgrim, you are now cooking with gas. The only thing holding you up is real life. The V divided by R equals A thing fails to take into account the physical limitations of friction and loss, let alone the mechanical limitations of components and design. These are considerable factors. Luckily for you, U.S. Amps overcompensates from this standpoint, and delivers TRUE RATED 2 ohm per channel performance. Most amplifiers are not built with the intestinal fortitude necessary to double PER CHANNEL power from 4 to 2 ohms, which as you see, QUADRUPLES your Bridged output. Don’t worry- U.S. Amps has you covered.

## GETTING WIRED

Once you have established the current needs of your system, it will be of the UTMOST IMPORTANCE to properly fuse the amplifier. Remember, power connections are always the last thing. There cannot be enough emphasis placed on the importance of proper fusing. Fuses prevent catastrophes. Always fuse each U.S. Amp product at or less than the recommended amperage. Another major consideration is wire. If you wish to build a truly high-powered system, you must take into account the total amperage requirements of the system and select your wire gauge accordingly. The following chart can be used as a guide:

### WIRE GAUGE AND AMPERAGE GUIDE

<b>AWG 14</b>	<b>30 AMPS</b>	<b>AWG 6</b>	<b>80 AMPS</b>	<b>AWG 0</b>	<b>190 AMPS</b>
<b>AWG 12</b>	<b>35 AMPS</b>	<b>AWG 4</b>	<b>105 AMPS</b>	<b>AWG 00</b>	<b>215 AMPS</b>
<b>AWG 10</b>	<b>45 AMPS</b>	<b>AWG 2</b>	<b>135 AMPS</b>	<b>AWG 000</b>	<b>245 AMPS</b>
<b>AWG 8</b>	<b>60 AMPS</b>	<b>AWG 1</b>	<b>160 AMPS</b>	<b>AWG 0000</b>	<b>275 AMPS</b>

These are real numbers, right out of the 1951 *U.S. Federal Electrician's Code Book*. It takes real wire to do real work. Trust us on this one.

## BATTERIES

Batteries, and the way they operate, is one of the least understood, yet critical element of any healthy car audio system. Even small, highly efficient systems need a minimum amount of amperage and voltage to operate properly. The average automotive battery is designed only to *start* the vehicle, not run the stereo, the lights, or anything else. That job goes to the vehicle alternator, once the engine has been started.

The alternator also recharges the battery, replacing the energy used to start the engine within a matter of minutes. The actual work done by the battery is minimal. If the current drawn by the vehicle lights and other electrical accessories does not exceed the amperage output of the alternator, the average battery will last for years.

The audio system, particularly the amplifiers, add to the current draw. Most stock alternators have excess output, anywhere from 30 to 50 amps, maybe more. A safe way to determine whether your electrical system is adequate to handle your U.S. Amp(s) is to use one-half of the amplifier fuse rating as a constant to determine the average current draw of the system. Unless you are one of those people who uses your amplifier to play a sine wave, (in which case you are on your own) your amp will not draw peak current all the time when playing music. This isn't rocket science, but it gets the job done. Another way is to use the charts on pages 10 & 11 to determine *actual amplifier output* based on the impedance that each channel is operating.

For each 100 watts, when playing music, count on  
7.5 amps average of average current draw.

## CARE AND FEEDING OF YOUR BATTERIES

As mentioned before, most batteries are built for the relatively light chore of starting the engine. Unless you have the room and ambition to install an upgraded high-powered alternator, your system current requirements may exceed the charging capability of your car's electrical system. When this happens, you have to rely on the vehicle battery(s) to make up the difference. Another factor to consider is voltage. Although the electrical system is considered to be "12 volt", the battery, when healthy, actually "rests" at 12.6 volts. The average alternator "puts out" 14.4 volts when the engine is on, because it is necessary to "feed" a battery higher voltage in order for it to charge.

## AMPLIFIER PROTECTION: SAT (Smart Amp Technology)

SAT is an exclusive U.S. Amps technology that continuously monitors amplifier functions to insure proper connection, supply voltage, and operating temperature. In the event of a fault condition SAT will trigger a protection circuit to immediately shut down the amplifier. Computerized SAT, available on the USA-150 and larger models, stores amplifier data and tracks specific faults by type and frequency for computer download and display. Never before has such a comprehensive analysis tool been offered on a car amplifier. Practical and useful, SAT is a *diagnostic and information retrieval system* that uses a programmable on-board computer to protect the amplifier from damage and permanently store vital information like:

***Amplifier model and serial number.***

***Date of manufacture.***

***Total hours, minutes, and seconds the amp has ever been on.***

***How often an individual channel has shorted.***

***How often the vehicle battery has gone under or over voltage.***

***How often the amplifier has gone into thermal protection.***

For the Authorized Dealer SAT provides real-time analysis and in-car diagnostics. The amp can be remotely triggered on by SAT, and at a glance the "live console" displays whether or not all amplifier systems are functional.

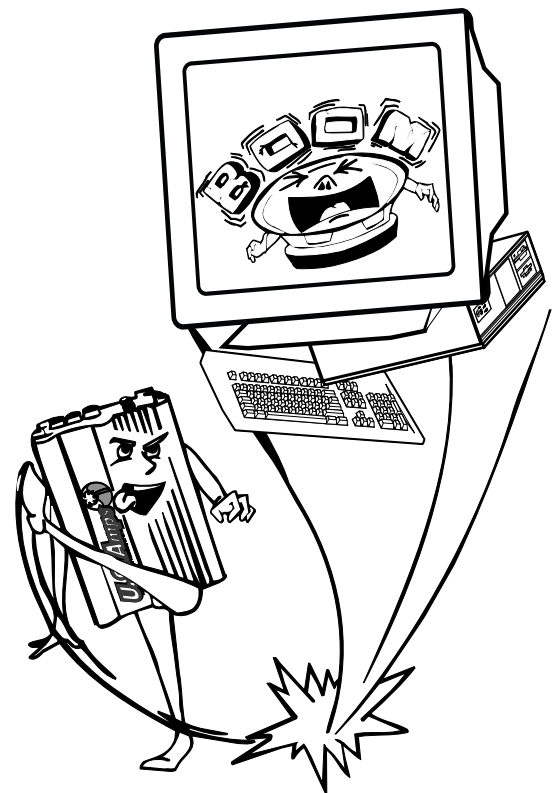



## AMPLIFIER POWER and FUSE Specifications\*

		Watts per Channel					
		4 Ohms	2 Ohms	1 Ohm	.5 Ohm	.25 Ohm	Fuse
<b>XTERMINATOR</b>	<b>200X</b>	50W	100W	N/A	N/A	N/A	25A
	<b>400X</b>	100W	200W	N/A	N/A	N/A	50A
	<b>600X</b>	150W	300W	N/A	N/A	N/A	75A
	<b>1000X</b>	300W	500W	N/A	N/A	N/A	135A
	<b>2000X</b>	500W	1000W	N/A	N/A	N/A	300A
	<b>4300X</b>	75W x 4	90W x 4	N/A	N/A	N/A	60A
	<b>5600X</b>	75W x 4 200W x 1	90W x 4 350W x 1	N/A	N/A	N/A	75A
<b>USA SERIES</b>	<b>USA-200</b>	25W	50W	100W	N/A	N/A	25A
	<b>USA-400</b>	50W	100W	200W	N/A	N/A	50A
	<b>USA-600</b>	75W	150W	300W	N/A	N/A	75A
	<b>USA-1000</b>	150W	300W	500W	N/A	N/A	135A
	<b>USA-2000</b>	250W	500W	1000W	N/A	N/A	300A
<b>COMPETITION</b>	<b>USA-50HC</b>	25W	50W	100W	188W	N/A	75A
	<b>USA-100HC</b>	50W	100W	200W	400W	N/A	225A
<b>BASS MEKANIKA</b>	<b>PT-350</b>	175W	N/A	N/A	N/A	N/A	35A
	<b>PT-800</b>	400W	N/A	N/A	N/A	N/A	80A
	<b>PT-1000</b>	550W	N/A	N/A	N/A	N/A	110A

Copyright 2001 U.S. Amps Inc. All rights Reserved. \*Specifications subject to change without notice.



## AMPLIFIER PERFORMANCE Specifications\*

	<b>Model</b>	<b>Bridged Output</b>	<b>THD @ 4 Ohms</b>	<b>S/N Ratio</b>	<b>Damping Factor**</b>	<b>Slew Rate</b>
<b>XTERMINATOR</b>	<b>200X</b>	200W @ 4 Ohms	< .006%	102dB	> 200	30Vus
	<b>400X</b>	400W @ 4 Ohms	< .006%	102dB	> 400	30Vus
	<b>600X</b>	600W @ 4 Ohms	< .006%	110dB	> 600	150Vus
	<b>1000X</b>	1000W @ 4 Ohms	< .006%	110dB	> 800	150Vus
	<b>2000X</b>	2000W @ 4 Ohms	< .006%	115dB	> 1000	150Vus
	<b>4300X</b>	180W x 2 @ 4 Ohms	< .006%	102dB	> 200	150Vus
	<b>5600X</b>	Not Bridgable	< .006%	102dB	> 200	150Vus
<b>USA SERIES</b>	<b>USA-200</b>	200W @ 2 Ohms	< .006%	102dB	> 200	30Vus
	<b>USA-400</b>	400W @ 2 Ohms	< .006%	102dB	> 400	30Vus
	<b>USA-600</b>	600W @ 2 Ohms	< .006%	110dB	> 600	150Vus
	<b>USA-1000</b>	1000W @ 2 Ohms	< .006%	110dB	> 800	150Vus
	<b>USA-2000</b>	2000W @ 2 Ohms	< .006%	115dB	> 1000	150Vus
<b>COMPETITION</b>	<b>USA-50HC</b>	375W @ 1 Ohm	< .006%	110dB	> 600	150Vus
	<b>USA-100HC</b>	800W @ 1 Ohm	< .006%	115dB	> 1000	150Vus
<b>BASS MECHANIX</b>	<b>PT-350</b>	350W @ 4 Ohms	< .05%	> 86dB	> 100	150Vus
	<b>PT-800</b>	800W @ 4 Ohms	< .05%	> 86dB	> 100	150Vus
	<b>PT-1000</b>	1100W @ 4 Ohms	< .05%	> 86dB	> 100	150Vus

Copyright 2001 U.S. Amps Inc. All rights Reserved. \*Specifications subject to change without notice.  
\*\*Measured at 4 Ohms at the circuit board.



# USA-200 / 200X USA-400 / 400X Controls and Features

## Built-in Active Crossover / Line Level Output:

The 2-way fixed-frequency 100Hz crossover can be configured to input the stereo high pass signal at 18db and output the summed-mono low pass signal at 24db to another amplifier, or vice-versa. The crossover can be defeated for full-range preamp output.

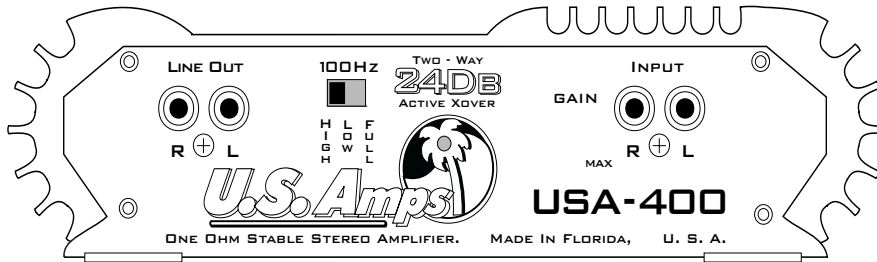

## Amplifier Input:

The USA-200 and 400 feature input isolation and a built-in voltage divider that will accept input signals from nearly any source. It is necessary to provide input to both channels when operating the amplifier. Input Sensitivity is variable from 250mv to 10 Volts.

**WARNING**  
U.S. Amps require a *grounded input connection*. DO NOT use ground-loop isolation devices on the input of your U.S. Amp!

## Power LED Indicator:

The green light in the middle of the palm tree is connected to the amplifier's power supply, and only lights when the amplifier is in working order.

## Gain Control:

The gain control is water and dust proof for long life and high fidelity. The input sensitivity can be infinitely adjusted from 250mv to 10 Volts.

## Smart Amp Technology:

Both models incorporate a non-computerized version of SAT (U.S. Amps' exclusive Smart Amp Technology) that precisely monitors each amplifier channel, the battery voltage, and amplifier temperature. In the event of a fault condition, SAT will activate to protect the amplifier from damage.

## Well-Engineered From Quality Materials:

The USA-200 and 400 feature Mil-Spec FR-4 plated-through circuit boards, stuffed with 1% tolerance parts and U.S. Amps' own hand-wound power transformers. The amplifiers are housed in a bead-blasted or custom polished anodized heat sink. The U.S. Amps logo is laser-etched or displayed on a Solid zinc emblem.

## Connections:

All power and speaker connections are via a heavy duty barrier terminal with gold plated hardware. Use at least 10 gauge wire for all power and ground connections.

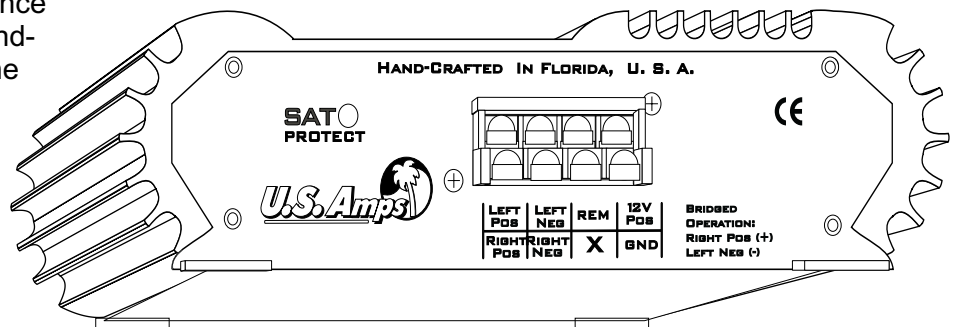

## Clear Plexiglas Bottom:

U.S. Amps are hand-crafted to a high standard of quality in our Gainesville, Florida factory, and are thoroughly inspected for both cosmetic and operational perfection. A clear bottom panel displays the attention to detail found in every U.S. Amp.

# USA-200 / 200X, USA-400 / 400X Stereo Operation

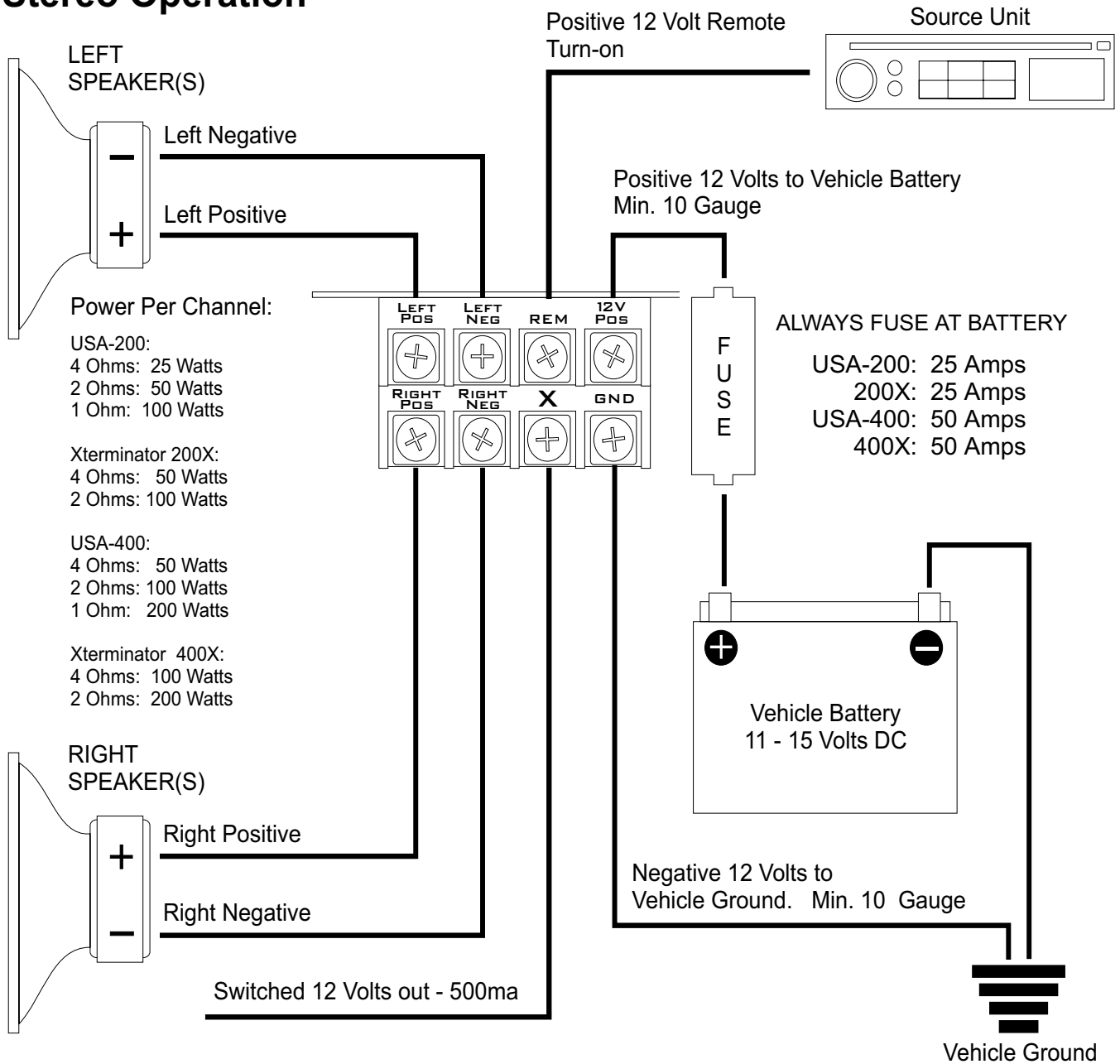

# Bridged Mono

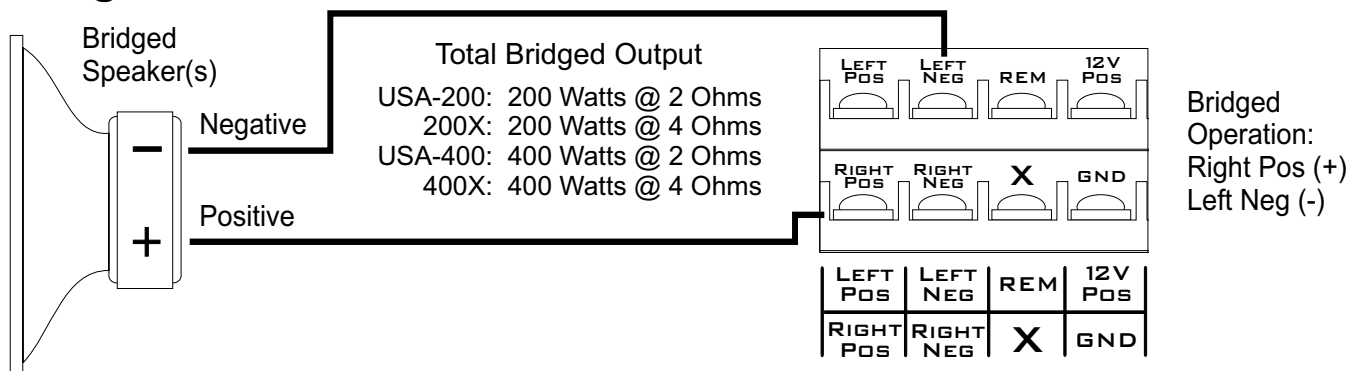



# USA-50HC, USA-100HC, USA-600, 600X, USA-1000, 1000X, USA-2000 and 2000X Controls and Features

## Amplifier Input:

These models feature input isolation and a built-in voltage divider that will accept input signals from nearly any source. It is necessary to provide input to both channels when operating the amplifier. Input sensitivity is variable from 250mv to 10 Volts.

## Active 24dB Low Pass Crossover:

The low-pass crossover can be infinitely adjusted to "roll off" at 24db per octave at frequencies between 50Hz and 500Hz. The crossover can be defeated for full-range operation.

**WARNING**  
U.S. Amps require a grounded input connection. DO NOT use ground-loop isolation devices on the input of your U.S. Amp!

## Gain Control:

The gain control is water and dust proof for long life and high fidelity. The input sensitivity can be infinitely adjusted from 250mv to 10Volts.

## Subsonic Filter:

To optimize amplifier power in the audible frequencies, a defeatable 36 Hz subsonic filter provides a 12dB per octave roll-off.

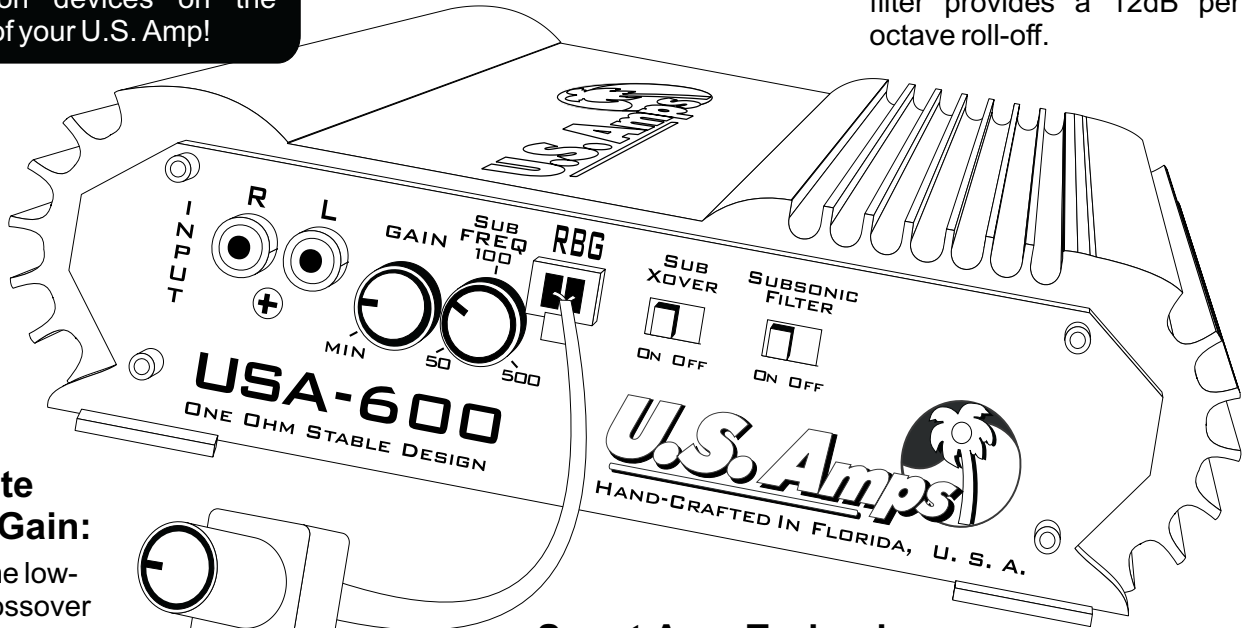

## Remote Bass Gain:

When the low-pass crossover is "ON" the amplifier volume can be adjusted remotely from the passenger compartment, independent of the system volume. The RBG works within the input volume range set by the GAIN control, and is about 75% effective. The RBG comes with a knob and 15' of cable.

## Clear Plexiglas Bottom:

U.S. Amps are hand-crafted to a high standard of quality in our Gainesville Florida factory, and are thoroughly inspected for both cosmetic and operational perfection. A clear bottom panel displays the attention to detail found in every U.S. Amp.

## Smart Amp Technology:

Both models incorporate a SAT (U.S. Amps' exclusive Smart Amp Technology) that precisely monitors and tracks vital amplifier information, including the type and frequency of fault conditions, battery voltage, and amplifier temperature. A built-in computer stores data that can be read by the Dealer with a U.S. Amps data port interface to aid in system problem-solving. In addition, SAT keeps permanent record of the amplifiers' serial number and time of operation.

**SAT**



**DATA  
OUT**

**EXCLUSIVE  
SMART AMP  
TECHNOLOGY**

# USA-50HC, USA-100HC, USA-600 / 600X, USA-1000, / 1000X Stereo Operation

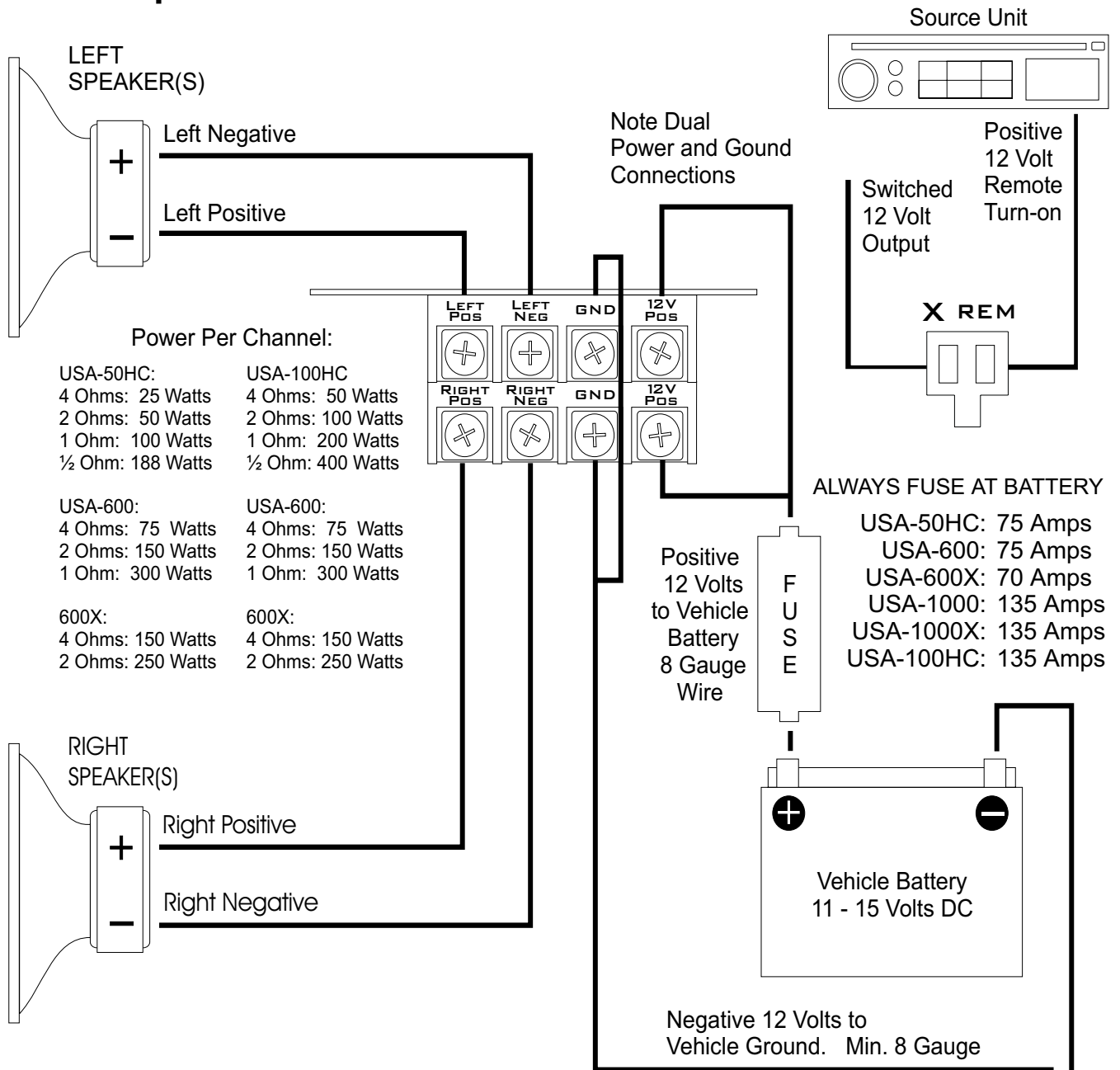

## Bridged Mono

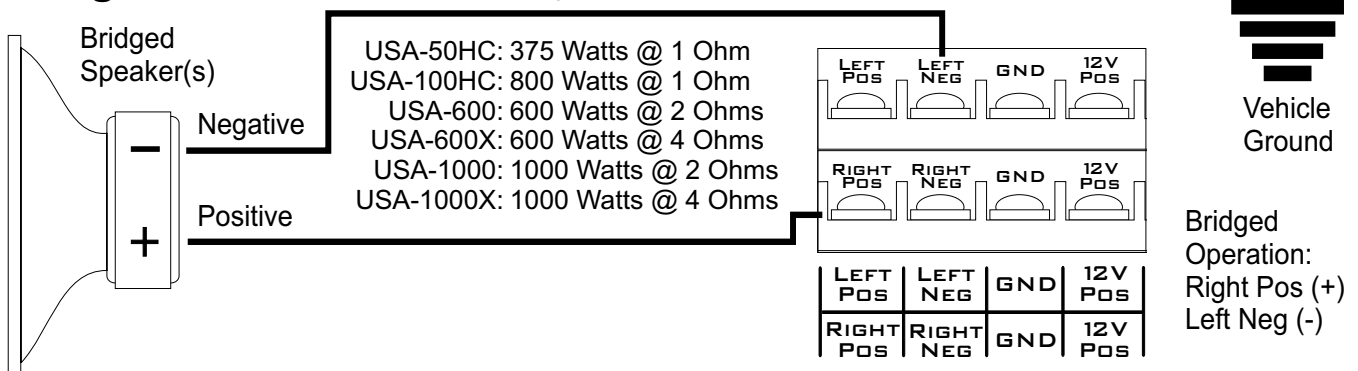

# USA-2000 and 2000X Stereo Operation

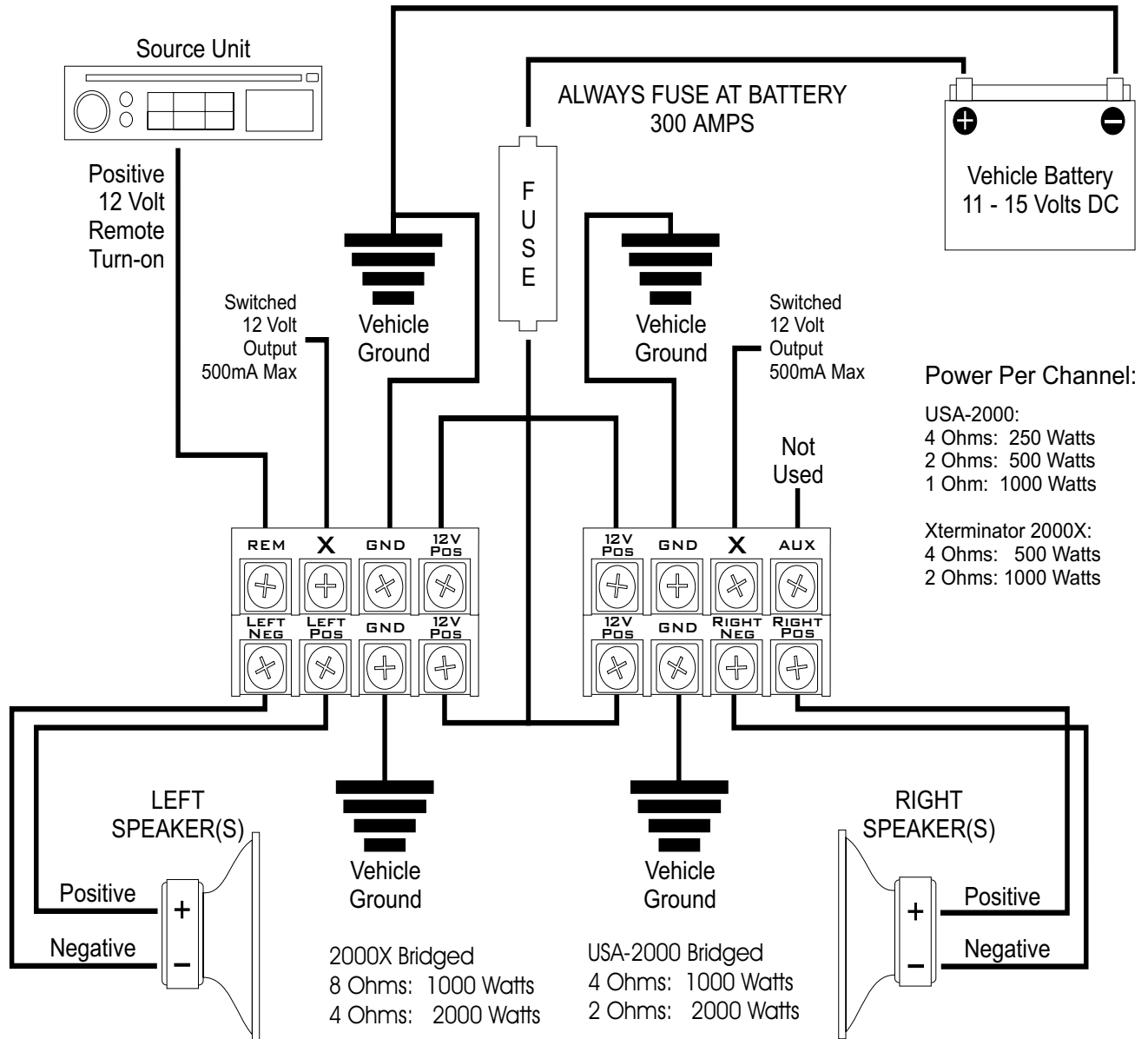

## Bridged Mono

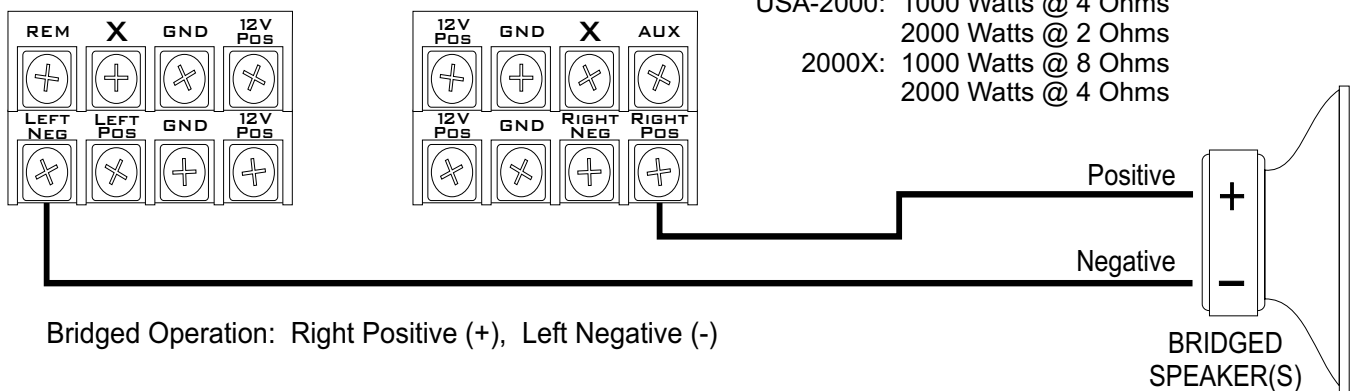



# 4300X Four Channel System Amplifier Controls and Features

The 4300X features a selectable two-way electronic crossover with independent front and rear mid-high frequency adjustment, two ohm per channel stability, and a Remote Bass Gain control that can be mounted in the vehicle passenger compartment. Power is provided by four 75 watt channels that can be bridged as front and rear pairs into a 4 ohm load for a total of 200 watts per bridged pair.

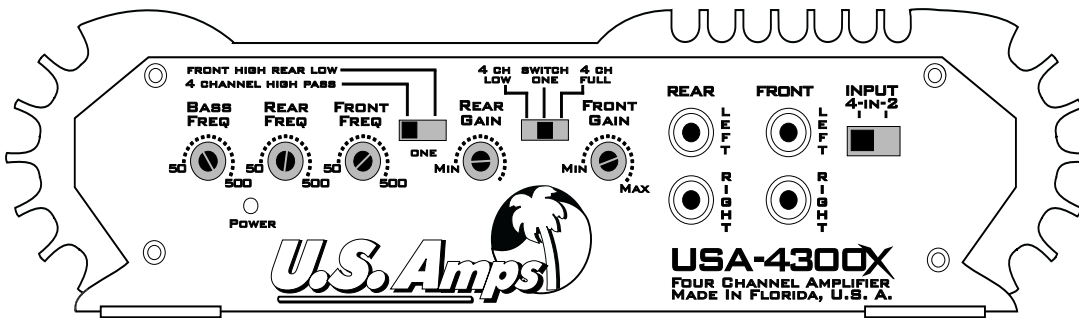

### 4-IN-2 Switch:

This switch allows the 4300X to accept either single or dual inputs, which provides front to-rear fading if the source unit is so equipped. Independent frequency controls adjust the “roll-off” of the high and low frequencies from 50Hz to 500Hz at 24 dB per Octave.

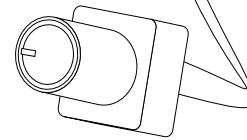

### Remote Bass Gain:

The 4300x comes with an optional “Remote Bass Gain” or “RBG” that can be mounted in the passenger compartment to independently attenuate the low pass output. The “BASS GAIN” located on the terminal end plate of the unit is used both to set the level of the low pass output and control the range of the RBG. It does not matter which way the RBG cable is connected. Use a common screwdriver tip or something like it to tighten the RBG knob.

### Crossover Settings:

The two-way crossover of the 4300X can be enabled to perform four separate functions by using the configuration switches on the amplifier end plate:

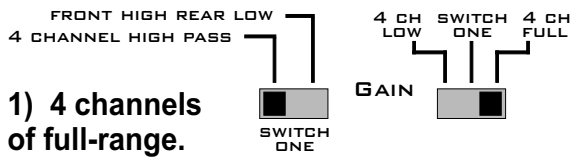

1) 4 channels of full-range.  
(Switch one is not in effect)

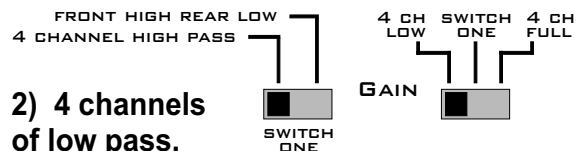

2) 4 channels of low pass.  
(Switch one is not in effect)

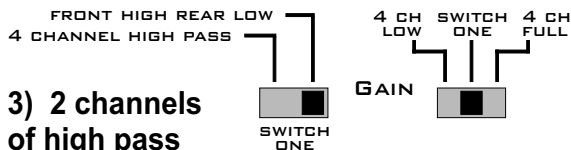

3) 2 channels of high pass and 2 channels of low pass.

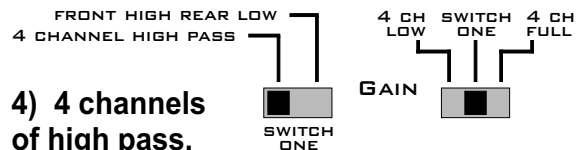

4) 4 channels of high pass.

# 4300X Four Channel Operation

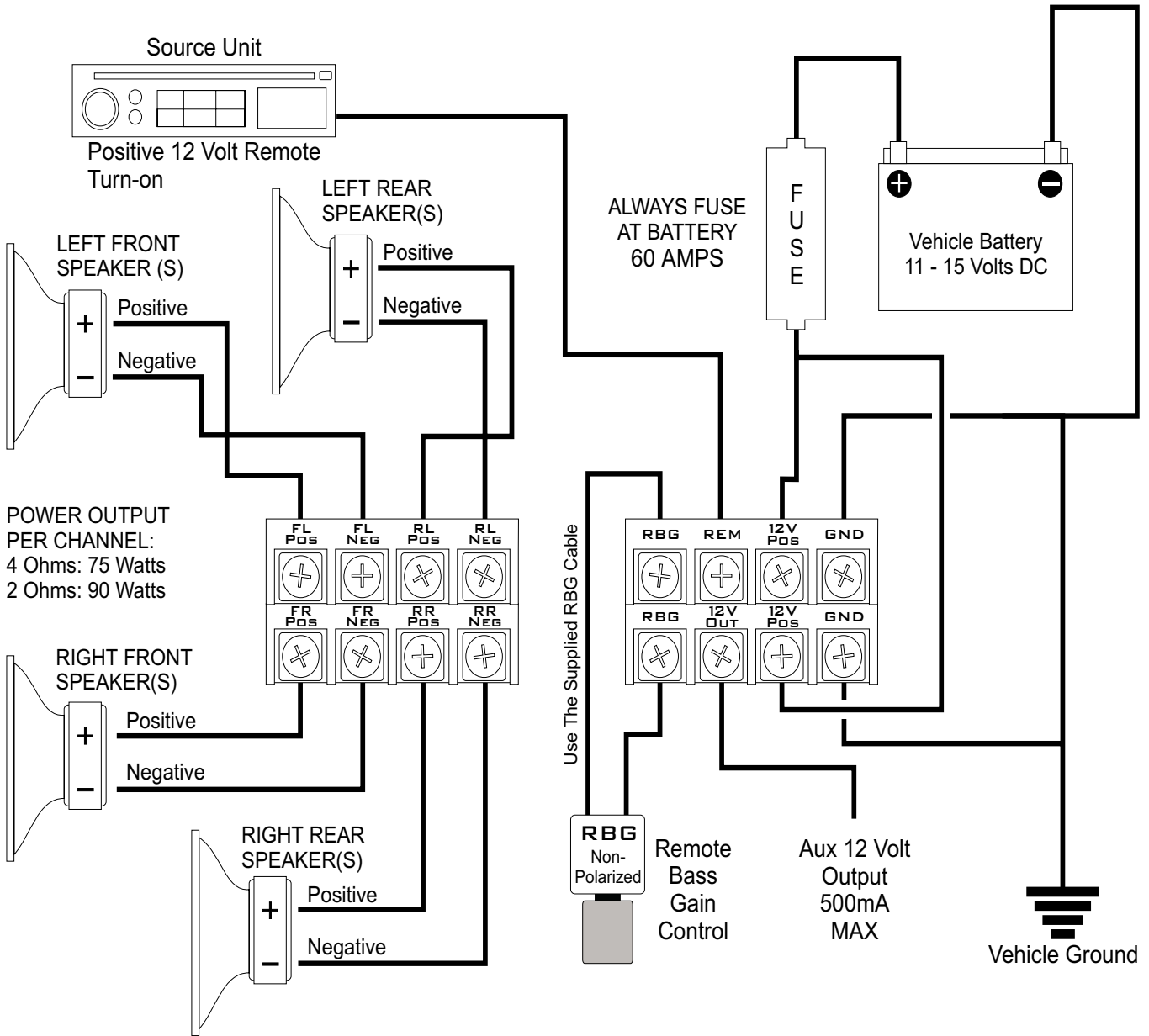

# 4300X Two Channel Bridged Operation

BRIDGED OUTPUT POWER PER CHANNEL:  
8 Ohms: 150 Watts  
4 Ohms: 180 Watts

**DO NOT OPERATE The 4300X BRIDGED MONO AT LESS THAN 4 OHMS PER BRIDGED CHANNEL!**

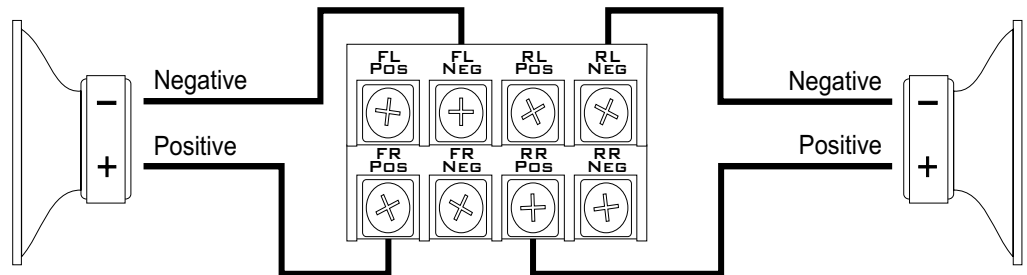

TO BRIDGE THE 4300X FOR TWO CHANNEL OPERATION USE THE RIGHT POSITIVE AND LEFT NEGATIVE OF THE FRONT AND REAR SPEAKER PAIRS



# 5600X Four Channel System Amplifier Controls and Features

The five-channel 5600X features a selectable three-way electronic crossover with independent front and rear mid-high frequency adjustment, dual power supplies, two ohm per channel stability, and a Remote Bass Gain control that can be mounted in the vehicle passenger compartment. The U.S. Amps logo comes separate in the box, so it can be mounted at the customers' discretion.

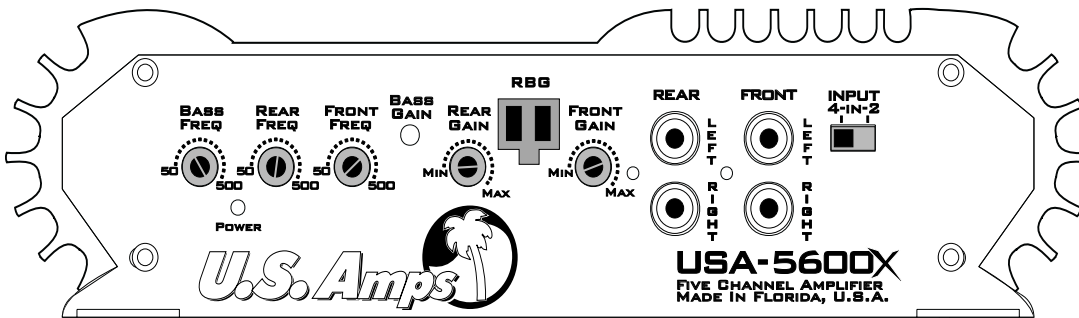

### 4-IN-2 Switch:

This switch allows the 5600X to accept either single or dual inputs, which provides front to-rear fading if the source unit is so equipped. Independent frequency controls adjust the "roll-off" of the high and low frequencies from 50Hz to 500Hz at 24 dB per Octave.

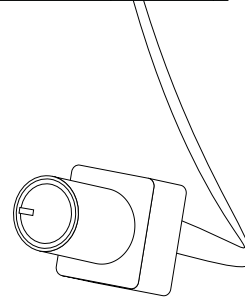

### Remote Bass Gain:

The 4300x comes with an optional "Remote Bass Gain" or "RBG" that can be mounted in the passenger compartment to independently attenuate the low pass output. The "BASS GAIN" slot located on the end plate of the unit is used both to set the level of the low pass output and control the range of the RBG. It does not matter which way the RBG cable is connected. Use a common screwdriver tip or something like it to tighten the RBG knob.

### Protection

The 5600X is protected against thermal, over and under voltage and short circuit. The separate power supplies of the 5600 are individually protected against over-current.

If the unit does not play on bass but the mid-highs work, or vice versa, check the "SAT PROTECT" LEDs at the terminal end of the amplifier. If one or both is lit, there is a speaker or wiring short, or improper speaker load in that area.



### Two Ohm Stability

All five channels of the 5600X are stable to two ohms. The power of the mid-high channels increase 17% from 4 to 2 ohms while the Subwoofer channel increases a whopping 43%!

### Amp Power @ 4 Ohms:

75 Watts x 4  
Plus  
200 Watts x 1

**500**  
TOTAL WATTS

### Amp Power @ 2 Ohms:

90 Watts x 4  
Plus  
350 Watts x 1

**710**  
TOTAL WATTS

# 5600X Five Channel Operation

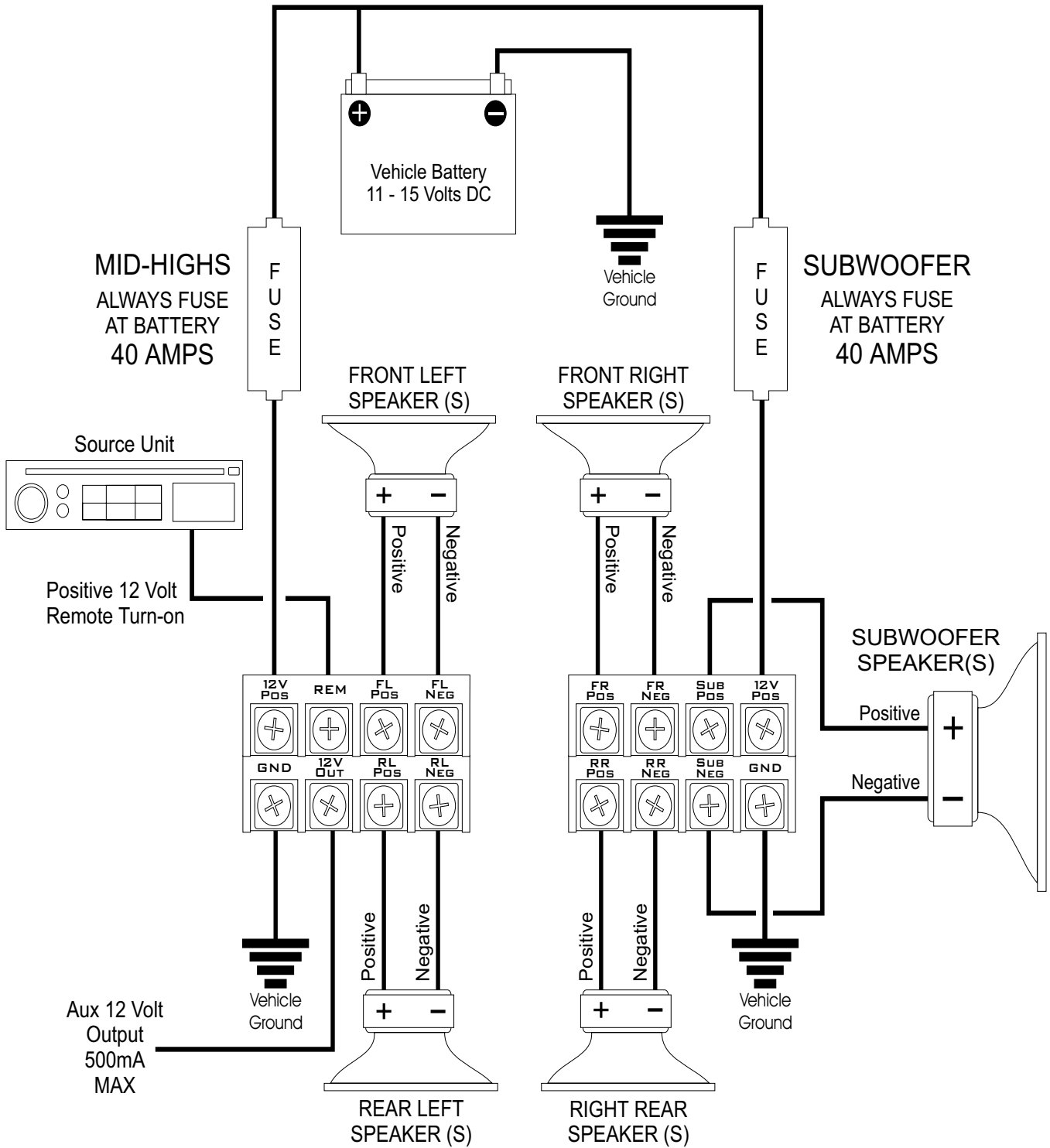

Terminal top view, facing the rear of the 5600X

# BASS MEKANIK BY U.S. AMPS

## T-CLASS™ EXPLAINED

U.S. Amps' "Bass Mekanik" amplifiers incorporate a revolutionary new method of Digital Power Processing™\*\*, a proprietary technology of Tripath Technologies that provides superior performance compared to conventional methods of amplification.

U.S. Amps T-Class™ digital amplifiers provide the full range high-fidelity of Class "A" and "A-B" designs, yet maintain the high-power digital efficiency of less sophisticated and less capable "Class D" amplifiers.



All "amplifiers" digital or analog, really consist of two sections, the *power supply* and the *amplifier section*. The *power supply*, or the "engine" of the amplifier, is highly efficient, losing little energy in the form of heat. The *amplifier section* acts as a "transmission" to convert the power supply's energy into audible sound.

It is during the analog conversion that the majority of amplifier heat and waste take place.

"Digital" amplifiers are high-speed, high-efficiency "transmissions". They work, or "switch" at much higher rates than analog amplifiers. Digital amplifiers allow more of the power supply's energy to the speakers with less heat and waste.

Both T-Class™ and "Class D" are over 80% efficient as a *whole*, (power supply waste included), compared to the 45 to 70% efficiency of a typical analog design.

### U.S. Amps' T-Class™ Verses "Class D"

Both types function on digital principals, where they virtually "skip" the analog conversion process of "Class A" and "A-B". It is *method* and *switching speed* that primarily distinguishes T-Class™ from "Class D" in performance.

#### "CLASS D":

"Class-D" amplifiers are unable to equal the performance of U.S. Amps T-Class™. The fundamental technology of "Class D" is self-limiting.

Here's Why:

"Class D" switching uses pulse-width modulation (PWM) technology. PWM switching is *relatively slow*, and *fixed* at a switching frequency anywhere from 75KHz to 200KHz. This produces audio output quality that is inferior to "Class A" or "A-B," so efficiency is gained at the expense of sonic fidelity.

# T-CLASS™ EXPLAINED - PART 2

A basic rule of thumb of audio amplifier design dictates that the *minimum circuit switching frequency* is *10 times greater* than the audible range. This bare minimum is necessary to keep transistor “switching noise” out of the audible signal.

To adequately reproduce the audible range, (20Hz to 20KHz) the “Class D” PWM would have to switch at a *minimum* of 200KHz, which represents the upper range (and cost) of PWM capability.

As a result,

“Class D” is generally used only in low frequency or low fidelity applications where the performance level of PWM is acceptable.

Large speakers - such as woofers, or inaccurate speakers like the full-range single cone drivers used in General Motors' *Delco-Bose™\*\*\** systems - help to hide the audible high frequency noise of “Class D” by virtue of their mechanical inability to reproduce high frequencies.

“Class D” is load-specific. Both “Class D” and *T-Class™* amplifiers require output filters to eliminate spurious digital “switching noise” from the output signal. The slow switching speed of “Class D” necessitates a large, built-in, high-value output filter that acts as a passive crossover and is dependent upon the correct speaker impedance.

Additionally, “Class D” operates at a relatively low voltage, much like a high current amplifier, and must be used into low impedances to make power with current. This emphasis on current requires a larger output filter that is more critical to impedance load matching.

This is why “Class D” amplifiers are specific “1 Ohm” or “1/2 Ohm”, etc. Failure to observe the exact recommended speaker load is akin to connecting an improper speaker load to a passive crossover network, and will result in degradation of the already limited “Class D” frequency response.

## U.S. Amps T-Class™:

To be sure, “Class D” is (was) a step in the right direction. It does work, and works rather well in certain instances. It is, however, a crude and incomplete technology when compared to T-Class™ and DPP. The underlying technology of U.S. Amps T-Class™ does not use PWM and is not pure analog. T-Class™ incorporates cutting-edge Digital Power Processing™ (DPP\*), a product of Tripath Technologies. DPP combines the benefits of *digital and analog* with a completely new approach.

U.S. Amps' T-Class™ amplifiers are among the first to apply this breakthrough technology.

DPP utilizes ultra-high speed digital switching that *varies* with the amplitude of the incoming signal. At rest, with no signal input, DPP switches at an *incredible 1.5 MEGAHERTZ!* (Wow!)

As the signal amplitude increases, the switching frequency of DPP decreases correspondingly, but never enough to degrade sound quality. DPP maintains an average switching frequency of 600 to 800KHz while sampling and switching audible frequencies.

This incredible sampling and switching speed gives U.S. Amps T-Class™ amplifiers their full-range characteristics, and requires a smaller and less restrictive output filter.

# T-CLASS™ EXPLAINED - PART 3

T-Class™ amplifiers operate at a much *higher voltage* than most “Class D” designs, producing more power into 8 and 4-ohm loads. Correspondingly, the T-Class™ output filter is much smaller than that used with “Class D”, allowing U.S. Amps T-Class™ to operate into various loads without affecting signal quality or frequency response in the audible range.

Typically, U.S. Amps' T-Class™ amplifiers have THD+N of less than 0.08% over the full audio bandwidth.

Additionally, U.S. Amps' T-Class™ exhibits ultra-low IHF-IM (high-frequency, inter-modulation) distortion - less than 0.04%. Low IHF-IM reduces “listening fatigue”, even at excessive volume levels. By any measure these superb specifications fall within the esoteric realm of audiophile performance.

U.S. Amps' T-Class™ provides power conversion efficiencies of 80% to more than 90%, equal to or better than “Class D”.

Another amazing but predictable benefit of T-Class™ is its cool operating temperature. When used within its designed power and load limitations, T-Class™ generates almost no heat. What little heat that is produced is quickly absorbed by the standard-size U.S. Amps heat sink.

U.S. Amps T-Class™ is the beginning of an audio amplifier revolution. Soon the consumer will have access to new and powerful products that will fit in confined spaces, require very little power to operate, and produce incredible full-range digital fidelity.

Like any technology, DPP can be painted as great or terrible, depending on the facts examined, ignored, or otherwise twisted in some marketing campaign. T-Class™ has a mediocre signal-to-noise ratio (86Db) when compared to analog amplifiers; due to a certain amount of high frequency “noise” present in the output content. This high-frequency “noise” is a signature of DPP technology, created by the terrific switching speeds, and is well above the audible range.

The high frequency content of T-Class™ is extremely tiny, only about 200mv, and impacts harmlessly on the speaker voice coils. By changing the output filter value it is possible to all but eliminate the switching noise, but doing so would have a slightly detrimental effect on two T-Class™ benefits, the full-range digital capability.

## **The Limitations of Digital Audio Amplifiers:**

Like any other amplifier design, it is possible to distort, or “clip” the output of a Digital amplifier.

What few people understand is that any digital amplifier design, T-Class™ included, loses much of it's efficiency benefits when it is used outside of it's intended operating range. When a digital amplifier “clips” or is driven into gross distortion, it starts to act more like a conventional class “A-B” design, both in power consumption and ugly waveforms.

A big reason that U.S. Amps' conventional class “A-B” amplifiers are successful in SPL competition against “Class D” products is our firm commitment to power supply technology. Once you exceed the “clean power” capability of any amplifier, it more or less lies down and lets the power supply do the work. U.S. Amps power supplies out-work the rest. Our oversized power supplies only enhance the capabilities of T-Class™ operation.

\* “T-Class” is a Trademark of U.S. Amps Inc.

\*\* “Digital Power Processing” is a Trademark of Tripath Technologies.

\*\*\* “Delco-Bose” is a Trademark of General Motors

# BASS MEKANİK PT-350

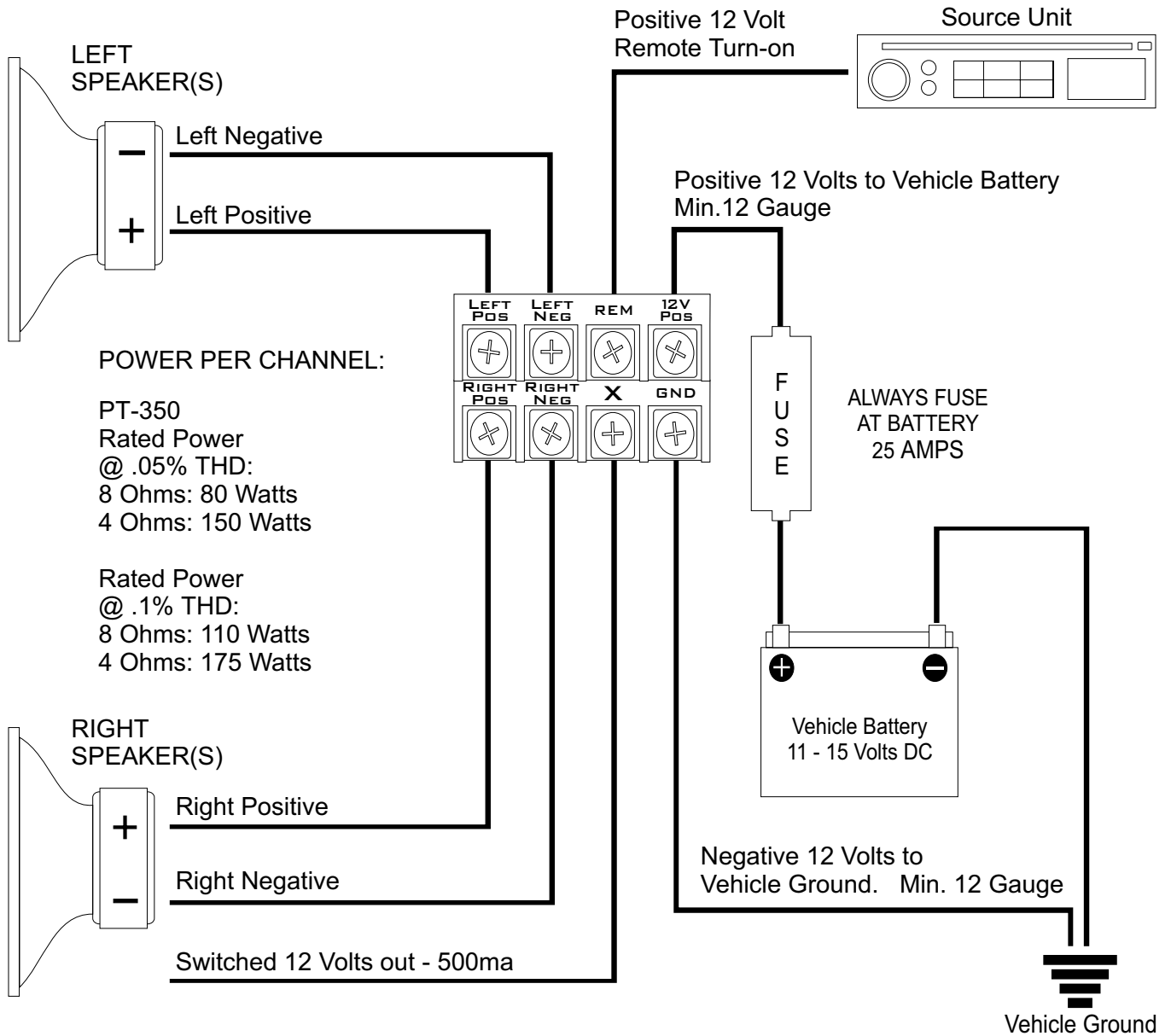

## 8 Ohms Bridged Mono

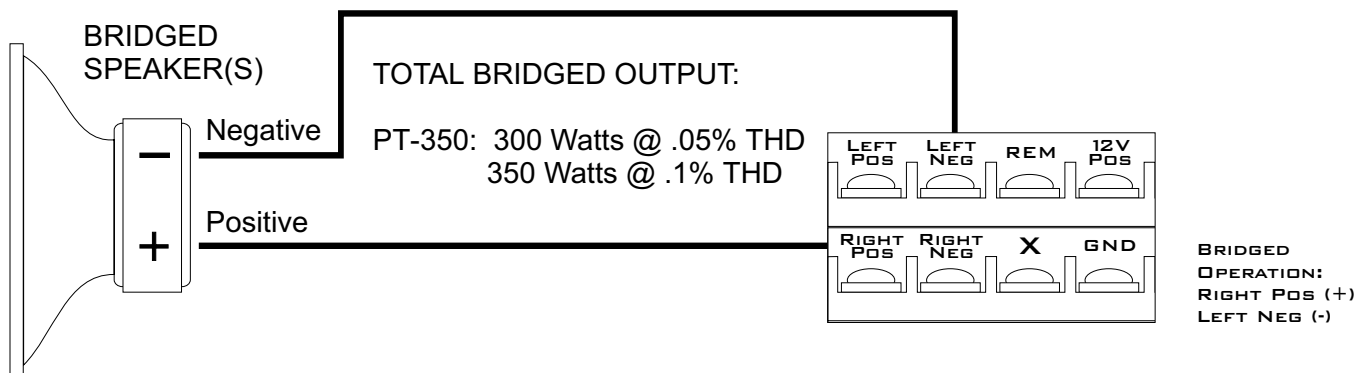

# BASS MEKANİK PT-800 AND PT-1100

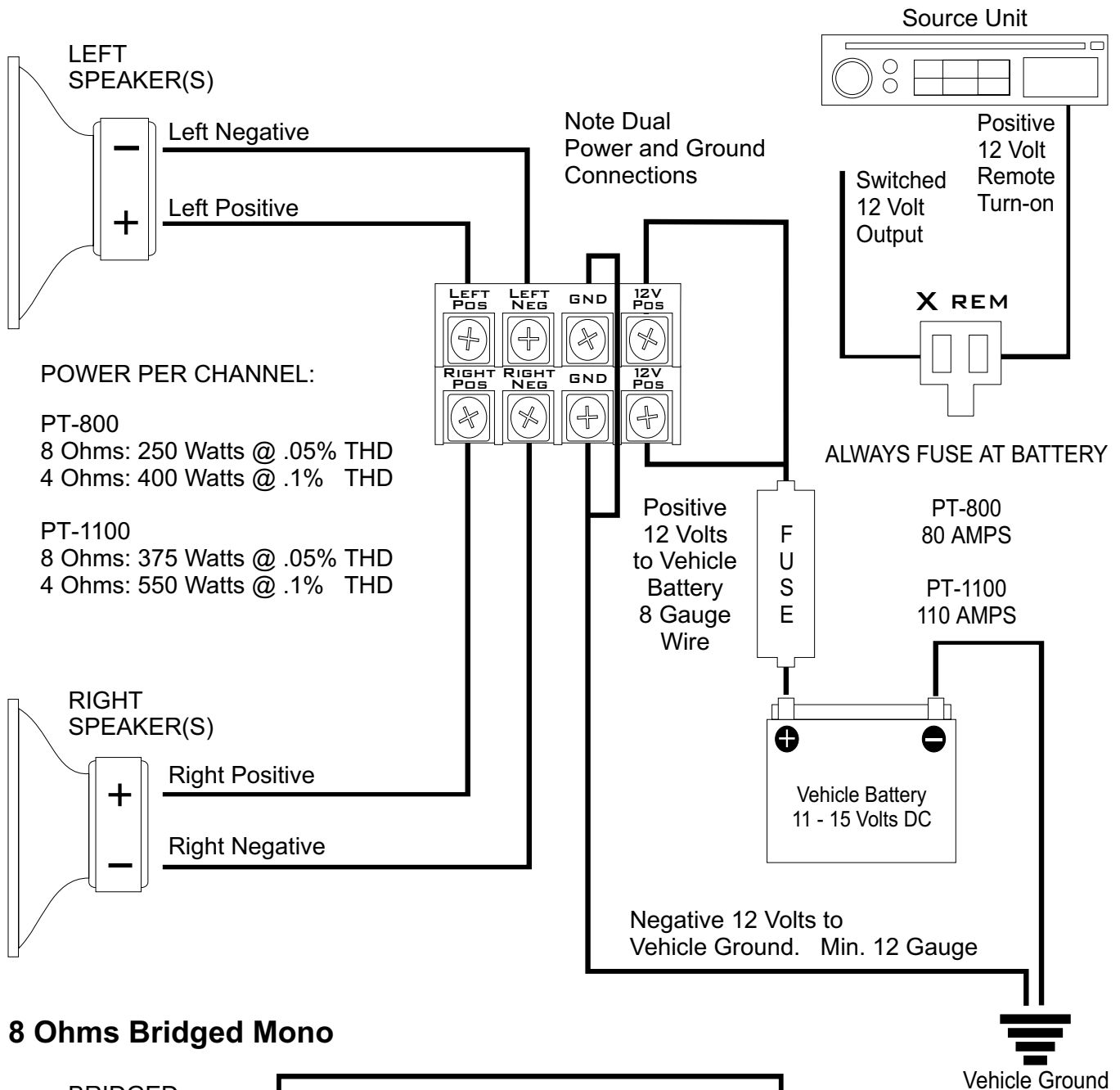

## 8 Ohms Bridged Mono

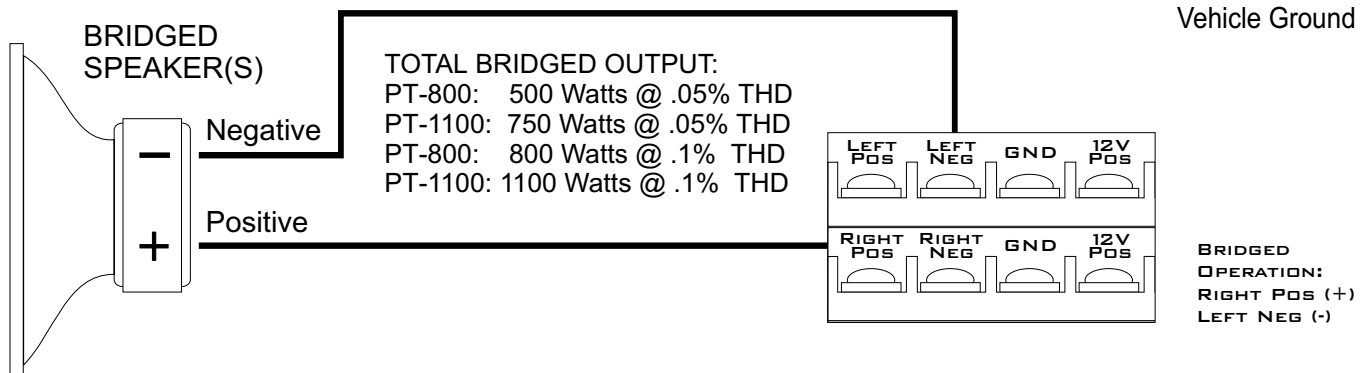

## Factory Service:

If you have a problem with your U.S. Amp that requires service you can either take it to the Dealer, who will send it back to the factory, or you can return it to the factory yourself. If you choose to send it in yourself you must first get a "Return Authorization" number from U.S. Amps that must be displayed on the outside of the shipping carton.

U.S. Amps will not accept packages for service that do not display a valid Return Authorization number. We don't like the red tape any more than you do, but it's the only way to keep things straight. There will be a charge for service unless the unit is under warranty and accompanied by a copy of the sales receipt. Remember to double box and insure your amp.

## Limited Warranty:

U.S. Amps Inc. warrants all manufactured electronic products to be free from defects in material and workmanship for a period not to exceed TWO YEARS from the date of purchase when installed by an Authorized U.S. Amps Dealer.

All other units not installed by an Authorized U.S. Amps Dealer maintain a warranty not to exceed 90 days from the original date of purchase by the original purchaser.

IMPORTANT WARRANTY NOTICE: U.S. Amps Inc. will only warrant and service product displaying valid U.S. Amps serial numbers. WARRANTY SERVICE WILL ONLY BE PERFORMED WHEN THE UNIT IS ACCOMPANIED BY A COPY OF THE ORIGINAL SALES RECEIPT. All product returned to U.S. Amps Inc. for service MUST be accompanied by a Return Authorization Number, issued by U.S. Amps Inc. in advance of shipment. The Return Authorization Number must be clearly and conspicuously displayed on the shipping carton or U.S. Amps Inc. will refuse delivery.

Return Authorization Numbers are available by calling (352)-338-1926 between the hours of 9:00am and 5:00pm EST.

This warranty extends only to the original purchaser and is not transferable. Defective equipment must be returned within the warranty period, freight prepaid, to the U.S. Amps Factory or an Authorized U.S. Amps Warranty Station. U.S. Amps Inc. will pay return freight on all warranty repairs.

This warranty covers only defects in materials and workmanship of manufactured electronic products, i.e. amplifiers and signal processors, and does not extend to batteries or other accessories bearing the U.S. Amps name. Incidents of misuse, abuse, neglect, or unauthorized modification will not be covered within the terms of this warranty.

U.S. Amps Inc. reserves the right to refuse warranty service under such conditions.

**U.S. AMPS INC. WILL NOT BE RESPONSIBLE FOR ANY DAMAGES, WHETHER INCIDENTAL OR CONSEQUENTIAL, RELATED TO THE USE OF THIS OR ANY OTHER PRODUCT BEARING OR SOLD UNDER THE U.S. AMPS BRAND NAME. USE THIS PRODUCT AT YOUR OWN RISK. IMPROPER USE OF THIS PRODUCT CAN RESULT IN PROPERTY DAMAGE, BODILY HARM, AND OR OTHER DAMAGE. U.S. AMPS INC. ASSUMES NO RESPONSIBILITY FOR YOUR HEALTH OR SAFETY.**

Any dispute arising from this warranty, or breach thereof, must be entered in the circuit court of Alachua County, Florida. This warranty gives you specific legal rights that may vary from state to state.

## NEVER NEVER LAND:

*NEVER* USE A U.S. AMP WITH A GROUND LOOP ISOLATOR OR AN ISOLATED INPUT SIGNAL. U.S. Amps are input-isolated at the factory and require an input ground for proper operation.

*NEVER* INSTALL OR MOUNT YOUR AMPLIFIER DIRECTLY TO A SPEAKER ENCLOSURE OR ANYWHERE ELSE WHERE SEVERE VIBRATION IS PRESENT. Protect your investment. Use common sense. Make sure the spot you choose is well-ventilated and free from dirt and moisture.

*NEVER* USE YOUR U.S. AMP BELOW THE RATED MINIMUM IMPEDANCE. Remember, when you bridge your amplifier, each channel "sees" one half of the load, hence at 4 ohms bridged each channel is operating at 2 ohms, which is the minimum impedance for XTERMINATOR models. U.S. Amps makes the USA Series of 1 ohm stable amplifiers if you wish to bridge into 2 ohms, plus an array of "high current" products that are purpose-designed to operate at even lower impedances. FAILURE TO OBSERVE THIS BASIC RULE WILL RESULT IN A SENSELESS WASTE OF POWER AND PERFORMANCE, and could damage your amplifier.



**YES!**  
I gotta have it!

Rush me the following cool U.S. Amps Items. Enclosed is my check or money order for the amount of \$\_\_\_\_\_ dollars.

NAME \_\_\_\_\_  
 ADDRESS \_\_\_\_\_  
 CITY \_\_\_\_\_ ST \_\_\_\_\_  
 ZIP \_\_\_\_\_ PH \_\_\_\_\_  
 Email Address \_\_\_\_\_

Send in this form with your order.

Make sure the amount on your check or M/O equals the GRAND TOTAL amount.

(Credit card purchases are available by calling the factory direct @ 352-338-1926)

## OTHER COOL STUFF ORDER FORM

ITEM (please circle size)	SIZE	EACH
U.S. Amps TEE	L, XL	\$20.00
U.S. Amps GOLF	L, XL	\$35.00
U.S. Amps JACKET	L, XL	\$85.00
U.S. Amps HAT		\$15.00
Team U.S. Amps VISOR STICKER		\$15.00
U.S. Amps EMBLEM		\$15.00
<b>GRAND TOTAL (Includes Shipping and Handling)</b>		_____



## OTHER COOL STUFF

Show your U.S. Amps Pride with your choice of these genuine high quality American-made accessories. Available at your Authorized U.S. Amps Dealer, or you can order factory-direct using the form on the back of this page



Team U.S. Amps  
Six Colors-Front Logo  
L, XL 100% Cotton

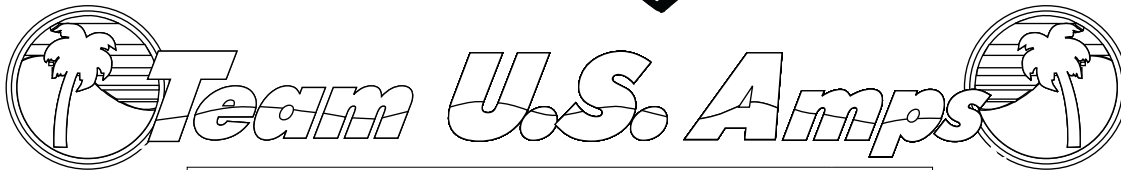

TEAM U.S. AMPS VISOR DECAL  
4 Color die-cut decal made of quality UV-resistant Material  
32"L X 4.5"T Beautiful Turquoise, Grey and Green.



Painted Metal  
U.S. Amps Emblem  
w/ Adhesive Back  
6.75"L X 2.5"H

Embroidered  
Hats and  
Golf Shirts  
Too!

We also have  
"Team U.S. Amps" Jackets  
In Black With a 5-Color  
embroidered logo  
Sizes L and XL

U.S. Amps Inc.  
7325-100 NW 13th Blvd  
Gainesville, Florida 32653  
(352)-338-1926 fax(352) 371-4122  
email: sales@usamps.com